

Promotion of energy efficiency in industries: Policies and experiences in India



by

K. K. Chakarvarti

**Bureau of Energy Efficiency
New Delhi**

**United Nations Forum on Energy Efficiency and Energy Security
for Sustainable Development: Taking Collaborative Action on
Mitigating Climate Change**

**17th December 2007
Seoul, Republic of Korea**



India's Energy Intensity is fifth lowest in the world

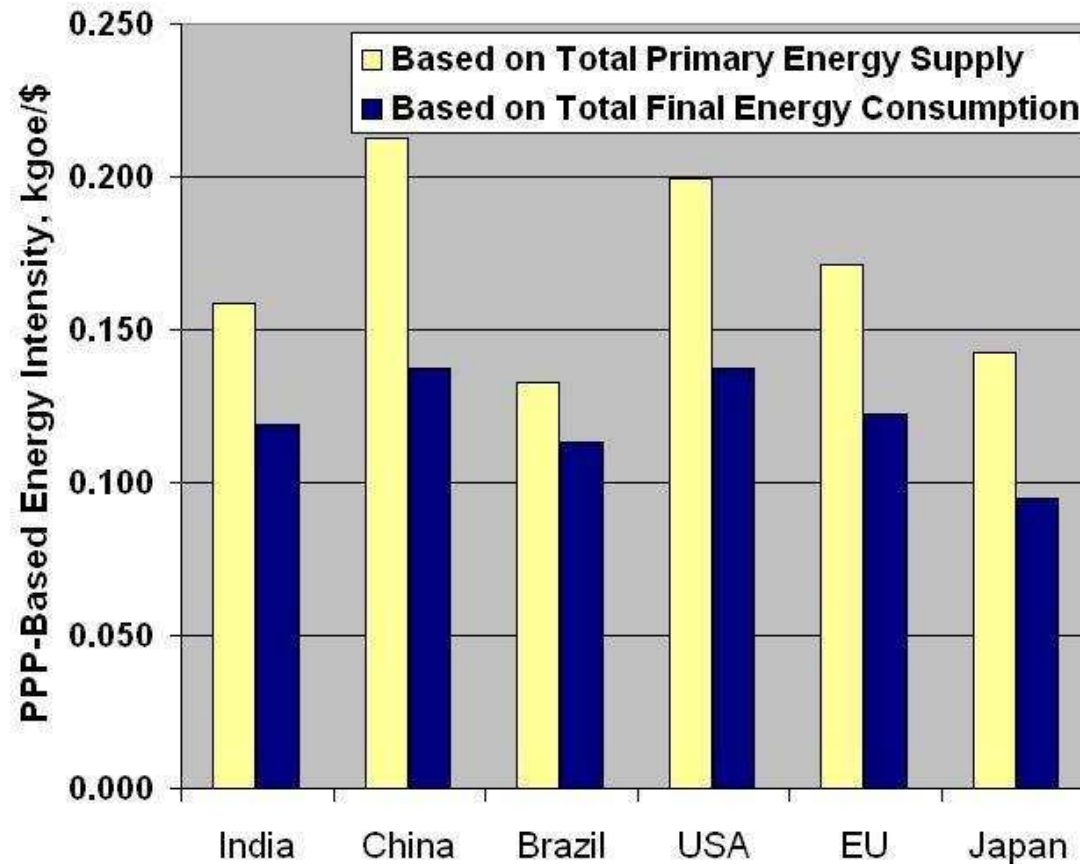

All data is for 2004

Ø Japan, Denmark, UK and Brazil have lower energy intensity

Ø Energy intensity is declining at about 1.5% per year



Energy Use in India

- Energy consumption in India is low, though efficiency of use is reasonable
 - Per capita energy consumption is 530 kgoe; world average is 1770
 - Energy intensity of Indian economy was 0.18 kgoe/\$-GDP(PPP) in 2004; compared to 0.14 in Japan and 0.19 in the EU
- Energy demand is increasing due to rising incomes, accelerated industrialization, urbanization and population growth
 - 2003-04 : 572 Mtoe
 - 2016-17 : 842-916 Mtoe
 - 2026-27 : 1406-1561 Mtoe
- Meeting the increasing demand only through increases in supply may lead to:
 - Reduced energy security due to volatility in availability and prices of imported fuels
 - Adverse environmental impacts
 - Strain on balance of payments
- Energy conservation and energy-efficiency are an essential part of national energy strategy

ENERGY CONSERVATION ACT - 2001

- Enacted in October 2001
- Become effective from 1st March 2002
- Bureau of Energy Efficiency (BEE) operationalized from 1st March 2002.

MISSION OF BEE

Develop policy and strategies with a thrust on self regulation and market principles, within the overall framework of the EC Act with the primary objective of reducing energy intensity of the Indian economy.



DESIGNATED CONSUMERS

(Energy Intensive Industries and other Establishments)

(A programme to initially focus on energy policy issues of energy efficiency improvement in organized sectors such as energy intensive industries and commercial sector through establishment of energy management system, capacity building of energy professionals, implementation of energy audits, establishments of specific energy consumption norms and support to consumers on providing information on authentic energy data)

- **Schedule to EC Act provides list of 15 energy intensive industries and other establishments to be notified as designated consumers (DC). DCs to**
 - **Appoint or designate energy managers**
 - **Get energy audits conducted by accredited energy auditors**
 - **Implement techno-economic viable recommendations**
 - **Comply with norms of specific energy consumption fixed**
 - **Submit report on steps taken**



Criteria for Notification for a Industry as Designated Consumer

1)	Thermal Power Stations- 30,000 metric tonne of oil equivalent (MTOE) per year and above
2)	Fertilizer- 30,000 metric tonne of oil equivalent (MTOE) per year and above
3)	Cement- 30,000 metric tonne of oil equivalent (MTOE) per year and above
4)	Iron & Steel- 30,000 metric tonne of oil equivalent (MTOE) per year and above
5)	Chlor-Alkali- 12,000metric tonne of oil equivalent (MTOE) per year and above
6)	Aluminium- 7,500 metric tonne of oil equivalent (MTOE) per year and above
7)	Railways- One traction substation in each Zonal Railway , Production units and Workshops of Indian Railways having total annual energy consumption of 30,000 MTOE or more under Ministry of Railways
8)	Textile-3,000 metric tonne of oil equivalent (MTOE) per year and above
9)	Pulp & Paper-30,000 metric tonne of oil equivalent (MTOE) per year and above



Designated Consumers –(contd.)

- **Draft Specific energy consumption norms for Cement and Paper & Pulp sectors have been developed**
- **Specific Energy Consumption norms finalization for two more sectors, namely Fertilizers and Chlor-alkali has been undertaken**
- **India is the only country to attempt to evolve mandatory absolute specific energy consumption norms for energy intensive industries under the Energy Conservation Act 2001 and regulate the market**
- **The principle of relative specific energy consumption norms, i.e annual % improvement based on a given as is situation in an enterprise is a more feasible option and may be more effective**



Designated Consumers –(contd.)

- To strengthen the energy management and energy auditing capabilities in the country, 5 National Certification examinations for Energy Managers and Energy Auditors have been successfully conducted in 2004, 2005, 2006 & 2007 (April & November) respectively in 23 centers all over the country.
- 2071 Certified Energy Managers and 2986 Certified Energy Auditors are in place from the last 4 certification examinations
- 61 energy auditing agencies have been accredited on the bases of their energy auditing capabilities and institutional set up.
- Accredited Energy Auditors have carried out about 3000 energy audits on voluntary basis in the last 3 financial years (2003-06).
- Energy saving to the tune of 2041 Million kWh, 750960 Tons of Coal, beside savings in oil and gas, equivalent to Rs.6488 Million have been recommended by 21 such agencies during the past 3 years.



Designated Consumers –(contd.)

Manuals and Codes

- Energy audits have been conducted with little or no standard test procedures and inadequate instrumentation.
- When Manuals of standardized test procedures are available and uniform codes are adopted, there would be increased awareness and clarity among users regarding the output from an energy audit.
- Further, energy auditors, as well as those utilizing their services, need to be made aware of the manuals and codes and of the need to adopt them in their professional work.
- Manuals and codes on 7 Technologies (Equipment) Lighting Systems; Dryers; Cogeneration Plants; Electric Motors; Electric Transformers; Fluid piping systems (network), insulation and Air Conditioners/Chillers (HVAC) have been prepared.
- The manuals and code would help in standardizing the process of energy audit to support energy manager and energy auditors

BEE Codes & Manuals

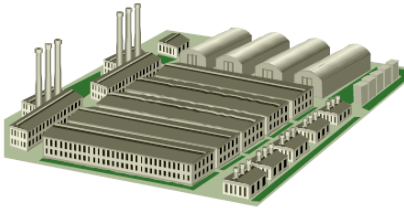

COGENERATION

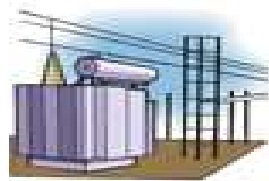

TRANSFORMERS

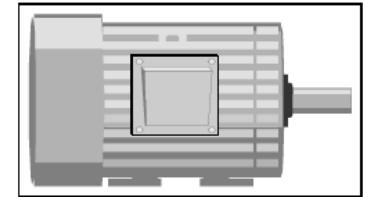

ELECTRIC MOTORS



HVAC-CHILLERS



FLUID PIPING SYSTEMS

BEE Codes and Manuals 2006
COGENERATION, DRYERS, ELECTRIC MOTORS,
FLUID PIPING SYSTEMS, HVAC CHILLERS,
LIGHTING, TRANSFORMER

ENERGY IS LIFE BUREAU OF ENERGY EFFICIENCY
Hall No. 4, 2nd Floor, NBCC Tower,
15, Bhikaji Cama Place
New Delhi - 110 066
www.bee-india.nic.in
www.energymanagertraining.com

CONSERVE IT

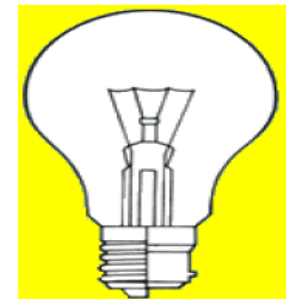

LIGHTING

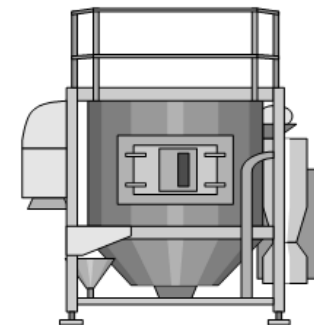

DRYERS



Industrial Energy Norms

- **Bandwidth of energy efficiencies in all sectors is large; old, low energy-efficiency units coexist with newer, state-of-the-art units**
- **7 Sector-specific task forces constituted:**
 - **Aluminium,**
 - **Cement,**
 - **Chlor alkali,**
 - **Fertiliser,**
 - **Pulp & paper,**
 - **Petrochemical & Refinery**
 - **Textile**
- **Draft Specific energy efficiency norms for Cement and Paper & Pulp sectors have been developed, which are now under discussion with the concerned sub sectors**
- **Energy efficiency norms based on current relative efficiency of units within a sector;**
 - **Highly energy-efficient units have lower improvement targets**
 - **Units with lower energy efficiency have more stringent improvement targets**



Energy Intensity is decreasing, but tail persists !

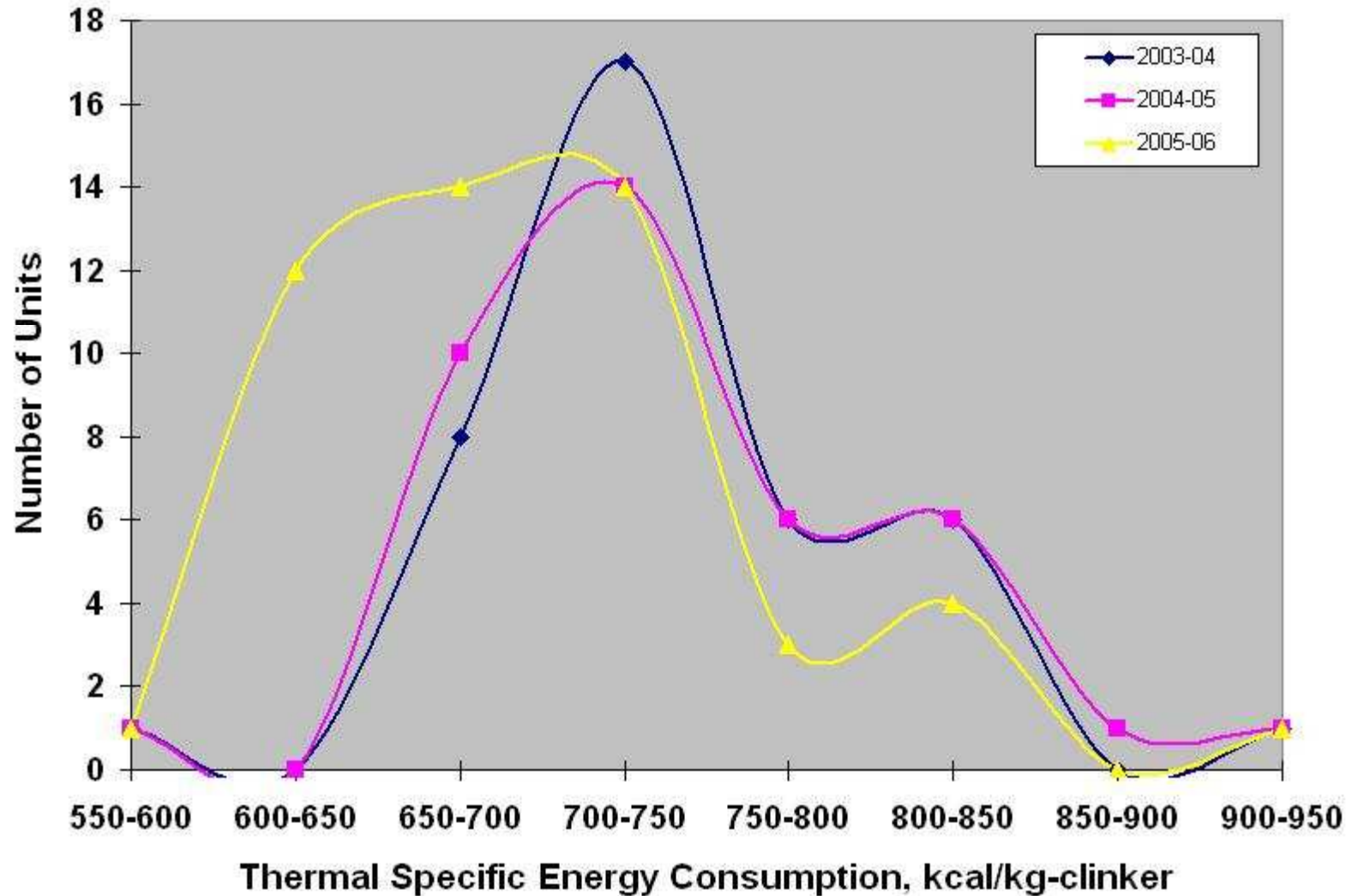

Go for Gold !

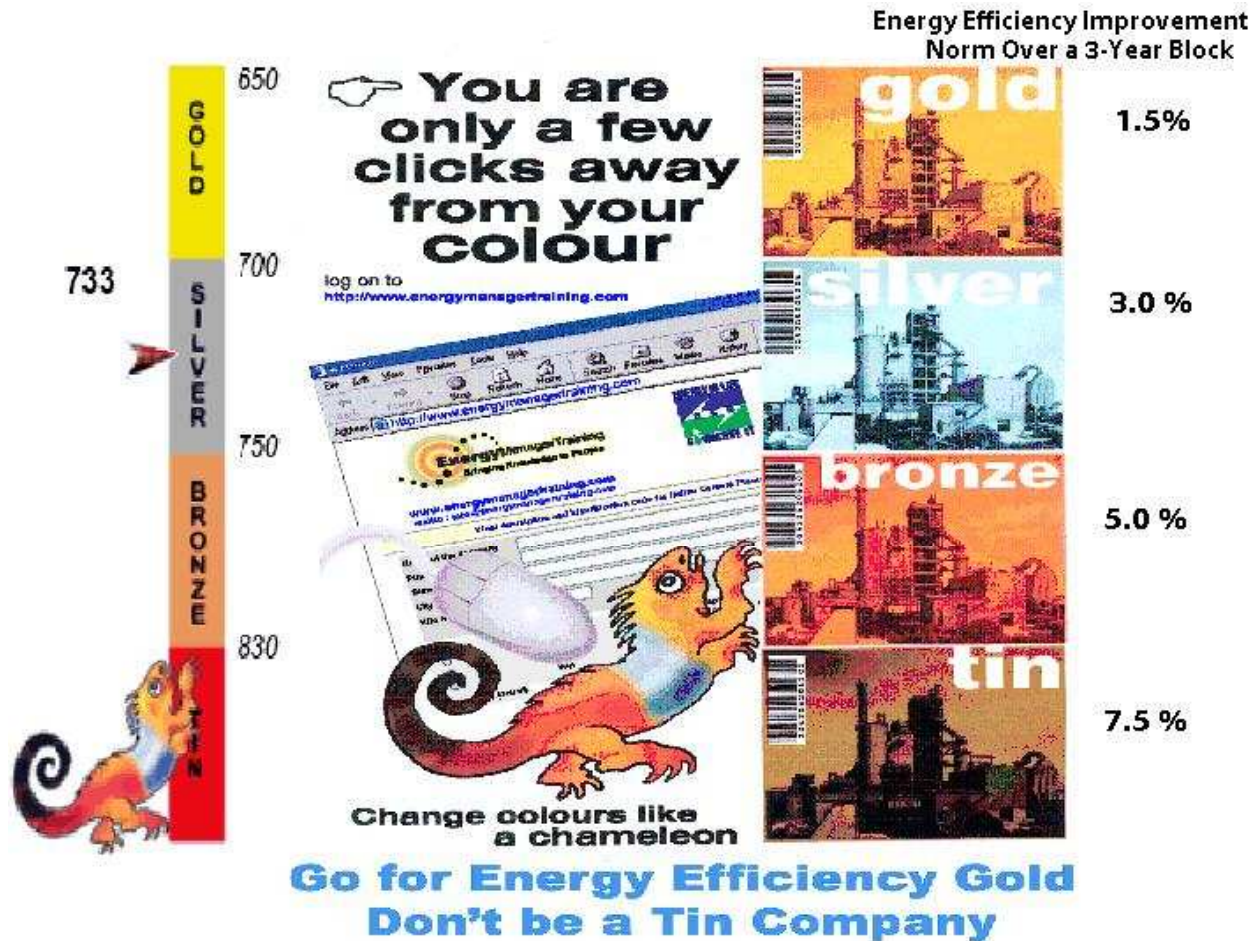

- Decrease the energy-efficiency bandwidth of the sector
- Tin tries harder than bronze, ... , Gold sets world standards



National Energy Conservation Awards



- **BEE coordinates this voluntary activity on behalf of Ministry of Power**
- **Due to consistent efforts put in by BEE, scheme has become very popular among industries, as is evident from increasing participation level**



NATIONAL ENERGY CONSERVATION AWARDS - 2007

- In the Awards Scheme 2007 for Large and Medium Scale Industry, applications were called from 33 sub-sectors of industrial units:
- automobile, aluminium, cement, chemicals, ceramics, chlor-alkali, consumer goods dairy, distillery & brewery, drug & pharmaceutical, edible oil/vanaspati, fertilizers, food processing (food & vegetable, marine products, package & food products, drinks & beverages) foundries, forging, glass, general category, integrated steel, jute industry mini steel, mining, paints & allied product industry paper & pulp, petrochemicals, petroleum pipeline, plastic industry refractory, refineries, steel re-rolling, sugar, tea, textile and tyre plants. (33 sub-sectors)
- For the Small Scale Sector, applications were invited from:
foundry, rolling mills and forging industry (3 sub-sectors)
- For the Building Sector, applications were invited from:
hotels, hospitals, office buildings and shopping malls
- For the railway sector applications were invited from:
zonal railways

Inviting leaders in the field
of Energy Conservation

NATIONAL ENERGY CONSERVATION AWARD 2007



FOR INDUSTRIAL UNITS, BUILDINGS AND ZONAL RAILWAYS

Ministry of Power invites applications from the Industrial Units, Office Buildings, Hotels, Hospitals, Shopping Malls & Zonal Railways which are making systematic attempts for efficient utilization and conservation of energy, for giving special awards for 2007 based on their performance during 2004-07.

The Salient Features of the Award Scheme

ELIGIBILITY

The scheme is open to all industrial units in the following sub-sectors of Large/Medium Scale Industry:

Aluminium	Automobile	Cement	Ceramics	Chemicals
Chlor-Alkali	Consumer Goods	Distillery & Brewery	Drugs & Pharmaceuticals	Dairy
Edible Oil	Fertilizers	Food Processing	Forging	Foundries
Glass	Integrated Steel	Jute	Mini Steel Plant	Mining
Paper & Pulp	Paints & Allied Products	Petrochemicals	Petroleum Pipeline	Plastics
Refinery	Refractory	Sugar	Steel Re-rolling	Tea
Tyre	Textile	General Category		

Awards will also be given to bonafide Small Scale Sector units in:

Re-rolling Mills	Foundries	Forging	General Category
------------------	-----------	---------	------------------

Buildings, in the following four categories and having Electrical connected load of 200 kW and above, are also eligible to participate in the Award scheme

Office Buildings	Hotels	Hospitals	Shopping Malls/Plazas
------------------	--------	-----------	-----------------------

A special scheme for recognizing the best work done in energy conservation by "Zonal Railways" under Indian Railways is also included in the Award Scheme.

If any unit does not fall under any of the above specified sub-sectors, the unit is encouraged to send its nomination under the "General Category"

AWARDS

- First and second prizes will be given in each sub-sector in the form of a Silver Plaque with appropriate citation on such awards.
- A unit getting the First Position for the third year in a row will be eligible for a "Top Rank Award" for that year. The units getting Second and Third Positions in that year will be given First and Second Prize respectively. Also, the Second Prize may be given to a unit for any number of years.
- The industrial unit eligible for Special Prize for 3rd year in a row would be given the highest prize, namely "Excellence Award" for its consistent performance.
- The performance of the units would be judged through Questionnaires, which would be evaluated by the Awards Committee.
- The Decision of the Committee will be final.

The Questionnaire can be downloaded from www.bee-india.nic.in and www.energymanagertraining.com

For obtaining copies of questionnaire, Please write to



Director (Energy Conservation)
Ministry of Power
F Wing, 2nd Floor
Nirman Bhawan,
New Delhi-110 011



Director General
Bureau of Energy Efficiency
(Ministry of Power, Government of India)
10th Floor, Sewa Bhawan
B.K. Puram, New Delhi - 110006
Tel. : 26179699 (5 Lines) Fax : 011-26178326 / 26178332
Website : www.bee-india.nic.in

The last date for
receipt of application is
24th October, 2007

SAVE ENERGY FOR BENEFIT OF SELF & NATION



The President, Smt. Pratibha Devisingh Patil presenting the National Energy Conservation Awards-2007 at the National Energy Conservation Day function, in New Delhi on December 14, 2007. The Union Power Minister, Shri Sushil Kumar Shinde is also seen.



Encouraging response from Indian Industry in the Energy Conservation Award Scheme (1999-2007)

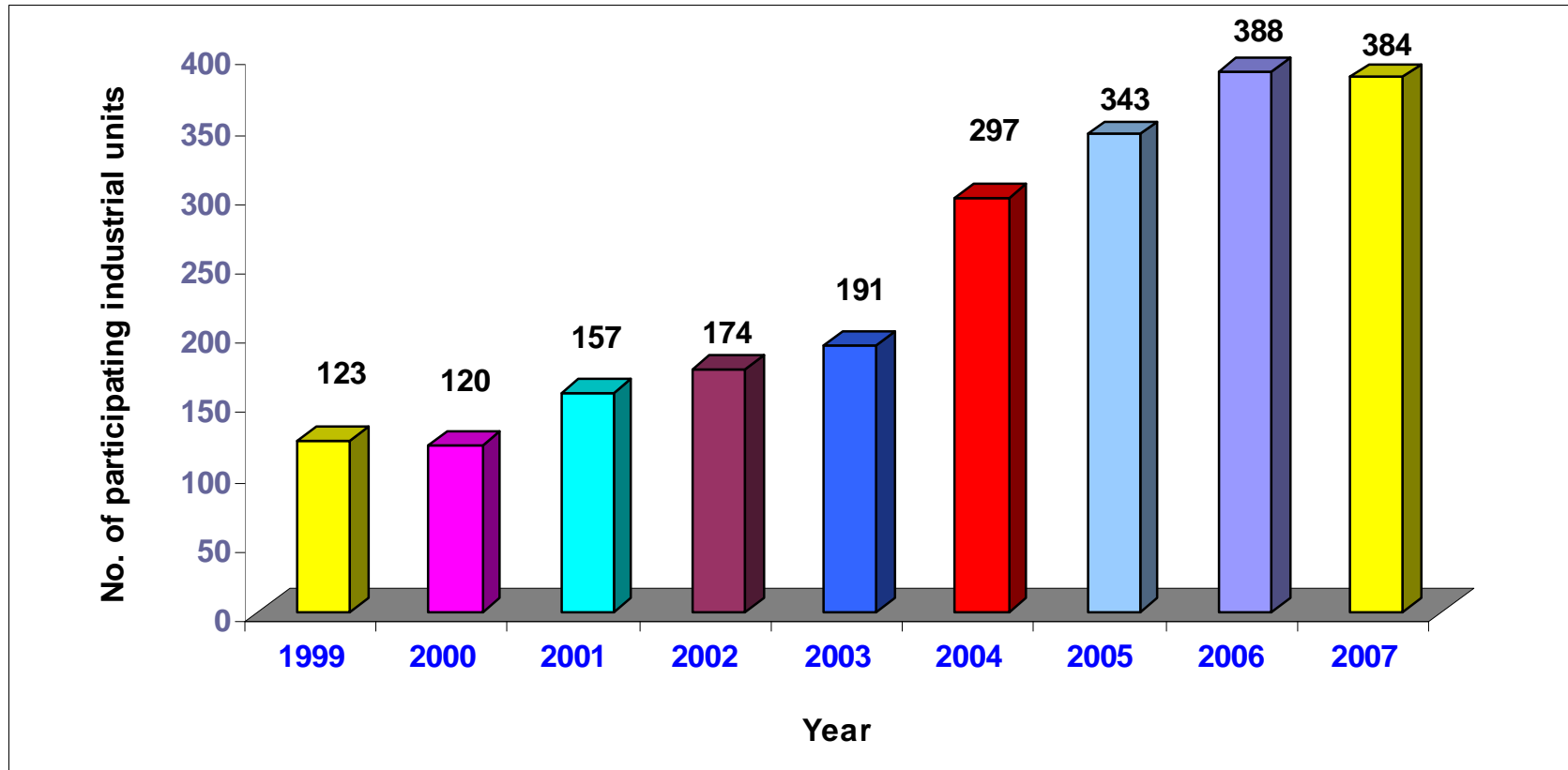



Electrical Energy Saving in terms of Equivalent Avoided Capacity in MW

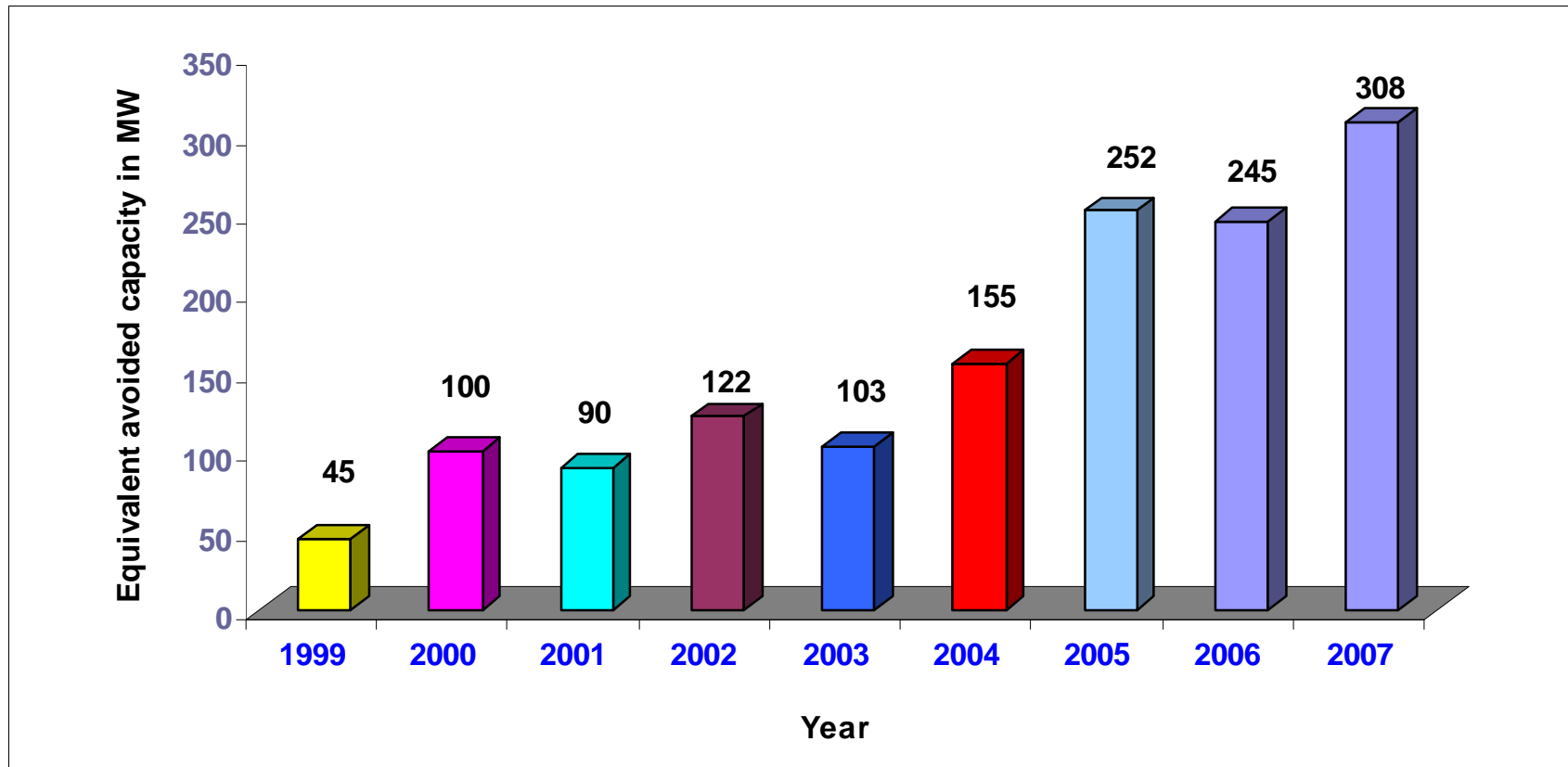



CONCLUSIONS

- *The increasing preference for commercial energy has led to a sharp increase in the demand for electricity and fossil fuels.*
- *Use of Fossil Fuels result in emission of huge quantity of carbon dioxide causing serious environmental damages.*
- *There is a considerable potential for reducing energy consumption by adopting energy efficiency measures at various sectors of India.*
- *Energy efficiency will not only reduce the need to create new capacity requiring high investment, but also result in substantial environmental benefits.*
- *With the enactment of the Indian Energy Conservation Act, 2001, an institutional framework is now available for promoting energy efficiency in all sectors of the economy*
- *Efficient use of energy and its conservation is succeeding as a program as now there is a strong institutional set up in the country and opinion leaders and captains of industry are taking lead in implementing the best practices supporting the conservation programme*

